

This article was downloaded by:

On: 22 January 2011

Access details: *Access Details: Free Access*

Publisher *Taylor & Francis*

Informa Ltd Registered in England and Wales Registered Number: 1072954 Registered office: Mortimer House, 37-41 Mortimer Street, London W1T 3JH, UK



## The Journal of Adhesion

Publication details, including instructions for authors and subscription information:

<http://www.informaworld.com/smpp/title~content=t713453635>

## Ultrasonic Evaluation of Adhesive Bonding

Y. Bar-cohen<sup>a</sup>; A. K. Mal<sup>b</sup>; C. C. Yin<sup>b</sup>

<sup>a</sup> Douglas Aircraft Company, McDonnell Douglas Corporation, Long Beach, CA, U.S.A. <sup>b</sup> Mechanical, Aerospace and Nuclear Engineering Department, University of California, Los Angeles, CA, U.S.A.

**To cite this Article** Bar-cohen, Y. , Mal, A. K. and Yin, C. C.(1989) 'Ultrasonic Evaluation of Adhesive Bonding', The Journal of Adhesion, 29: 1, 257 – 274

**To link to this Article:** DOI: 10.1080/00218468908026491

**URL:** <http://dx.doi.org/10.1080/00218468908026491>

PLEASE SCROLL DOWN FOR ARTICLE

Full terms and conditions of use: <http://www.informaworld.com/terms-and-conditions-of-access.pdf>

This article may be used for research, teaching and private study purposes. Any substantial or systematic reproduction, re-distribution, re-selling, loan or sub-licensing, systematic supply or distribution in any form to anyone is expressly forbidden.

The publisher does not give any warranty express or implied or make any representation that the contents will be complete or accurate or up to date. The accuracy of any instructions, formulae and drug doses should be independently verified with primary sources. The publisher shall not be liable for any loss, actions, claims, proceedings, demand or costs or damages whatsoever or howsoever caused arising directly or indirectly in connection with or arising out of the use of this material.

# Ultrasonic Evaluation of Adhesive Bonding\*

Y. BAR-COHEN

*Douglas Aircraft Company, McDonnell Douglas Corporation, Long Beach, CA 90846, U.S.A.*

A. K. MAL and C.-C. YIN

*Mechanical, Aerospace and Nuclear Engineering Department, University of California, Los Angeles, CA, U.S.A.*

*(Received July 21, 1988; in final form January 31, 1989)*

The capabilities of existing ultrasonic nondestructive evaluation (NDE) methods for the strength-related properties of bonds in structural components is reviewed. The severe limitations of conventional NDE methods in yielding quantitative results are indicated. Some recent results of a joint theoretical and experimental program of research using leaky Lamb waves (LLW) in laboratory specimens are presented. The LLW technique is shown to have several advantages over conventional techniques. Potential applications of the technique to determine non-destructively the quality of bonds in a variety of models are discussed.

**KEY WORDS** NDE; adhesive bonding; interfaces; ultrasonics; leaky Lamb waves (LLW); dispersion.

## INTRODUCTION

Adhesives are a means of maintaining structural integrity and transferring loads between the components of an assembly. With bonding increasingly used in flaw-sensitive structures with complex configurations, there is a need for highly reliable NDE methods to evaluate bond performance. The simplest and most commonly used technique is tap testing, in which the inspector taps the test structure with a hammer or a coin and listens to the characteristics of the sound. While this method is fast and simple, it is very limited in scope and can only be used to detect gross unbonds.

Cawley and Adams<sup>1</sup> made a systematic study of the tapping method by examining the force input by the tapper to the test structure. They found that the characteristics of the force input to a structure by a tap are changed by an

---

\* Presented at the 35th Sagamore Army Materials Research Conference, Manchester, New Hampshire, U.S.A., June 26–30, 1988.

unbond. Further, the impact duration increases and the peak force decreases as the defect becomes larger. Even though this resulted in a substantial improvement in the reliability and detectability of the technique, it is still limited to thin layers (less than or equal to 1 mm) and the smallest detectable unbond is 10 mm in diameter in typical test specimens.

The performance of a bond can be ensured only with a method that detects and characterizes unbonds as well as determines the properties of the adhesive. The ultimate need is to measure, nondestructively, the strength of the bond. To attain this capability, parameters that might be sensitive to strength have been sought by many investigators.<sup>2</sup> Limited success was achieved for cases in which the material variables were carefully controlled, and where there was a direct relationship between the average strength and a single property of the adhesive material, such as thickness. However, in practice, it is difficult to correlate NDE data with the strength of a bond. This is due to the fact that strength is not a physical parameter but a structural one and, in fact, is an indication of the highest stresses that the weakest spot of a specific structure is able to carry. Generally, there is no NDE method that can search systematically through a structure to identify all the weak points and determine which is the weakest one. Further, bonding is particularly sensitive to interface characteristics which cannot, at present, be determined nondestructively. Therefore, even though it may be possible to estimate the average strength of a bonded system, the usefulness of this measure is debatable at best. The bond will simply fail when the stress exceeds the material strength in its weakest spot rather than the average strength, which may be substantially higher.

The strength of an adhesive bond depends on two factors, cohesion and adhesion. Cohesion is associated with the bond between the various molecules of the adhesive layer. Cohesive strength is related to the type of the adhesive, its elastic properties, its thickness, the presence of defects, etc. Limited information can be obtained about some of these parameters when using NDE methods. On the other hand, adhesion is related to the bond between the adhesive and the adherents. The quality of the adhesion is critical to the performance of the adhesive as a bond between the components of an assembly. Since the interface layer is often a fraction of a micrometer thick, it is very difficult to characterize it nondestructively. Weakness of this layer, which can be caused by poor surface preparation, is not detectable by an existing NDE method. In some cases, such as in diffusion bonding and steel/rubber bonding, weak adhesion can also be the result of a myriad of minute separations over a certain area. This type of defective area has a potential for being measured nondestructively in terms of the average degree of separation, rather than the weakness of bond.

Due to the above limitations in the determination of strength, NDE methods are used to detect and characterize unbonds rather than bond strength. Acoustics and ultrasonics currently serve as workhorses in NDE of unbonds. The methods of resonance, pulse-echo, through-transmission, ultrasonic spectroscopy, and leaky Lamb waves (LLW) are the most useful ones and they are reviewed in this subsection.

## RESONANCE

Accessing the part from one side and using a single frequency, one can employ the resonance method to inspect bonding. This method is based on establishing a standing-wave in the test material when the effective thickness of the test material is equal to an odd multiple of the wavelength of the propagating wave.<sup>3</sup> The effective thickness of the test material is inversely related to the resonant frequency and, therefore, an unbonded material gives rise to a higher resonant frequency. The change of frequency can be determined by measuring its loading effect on piezoelectric transducers. This effect can be analyzed using transmission-line theory, where the test material serves as a termination. The transducer's electrical impedance and its resonant frequency are affected by the load. Their values for bonded materials can be used as a reference when searching for unbonds.

To determine the effect of the unbond on the induced ultrasonic wave, the wave behavior needs to be analyzed. At low frequencies (in the kHz range) the attenuation in the test material can be neglected. Assuming a plane wave at normal incidence, the acoustic pressure can be related to the particle velocity through the acoustic impedance,  $z$ , where<sup>4</sup>

$$z = \rho v \tanh[\alpha + i(\beta + kd)] \quad (1)$$

In Eq. (1)  $\rho$  is the material density;  $v$ , the acoustic wave velocity;  $\alpha$ , the reflectivity constant;  $\beta$ , the change in phase;  $d$ , the distance traveled by the wave within the material; and  $k$ , the wavenumber.

The change in the acoustic impedance of a test specimen due to unbond changes the electric impedance of the transducer that is loaded by the material. The change in the load depends upon the distance traveled in the material, namely, the effective thickness, causing an appropriate change in  $z$ . A proper selection of the test frequency allows an increase in the response to unbond, and this is done during the instrument calibration.

The use of resonance as an NDE technique for detection of unbonds is based on the difference in the characteristic response between bonded and unbonded areas. Several commercial instruments have been developed in recent years. The instruments are calibrated by using the response from a bonded or an unbonded area as a reference. Two commonly used instruments are the Bondascope 2100 and the Fokker Bondtester.

The Bondascope 2100 (NDT Instruments, Inc.) displays the transducer's electrical impedance at selected frequency as a point on the complex plane. Figure 1 shows a typical response to loading a transducer by bonded and unbonded metal-to-metal areas of a test sample. In this figure, three impedance points are shown on the CRT representing; (1) air loading, where the transducer is not loaded, (2) unbonded layer of aluminum, and (3) a bonded system of two aluminum plates. The difference in the transducers' impedance as a result of the change in loading is easily distinguishable.

The Fokker Bondtester (Fokker Instruments) displays the impedance ampli-

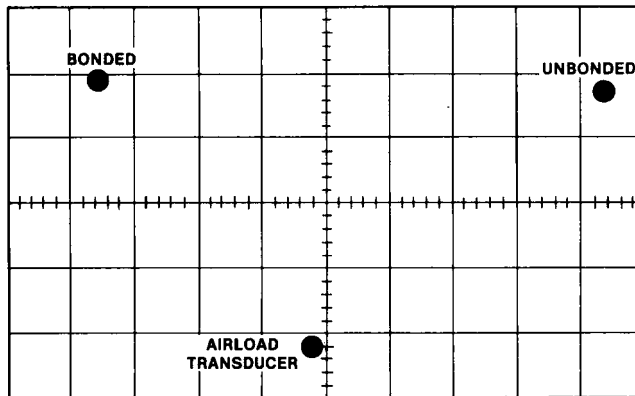

FIGURE 1 A display of the transducer impedance from the Bondascope 2100.

tude and phase as a function of frequency on two different indicators providing an additional control. Using this bondtester, it has been shown that the change in each of the parameters is related to the change in adhesive layer thickness.<sup>5,6</sup> Since the thickness of the adhesive can be correlated to the bond strength (Figure 2), the instrument was suggested as a means of bond strength measurement. The correlation is shown in Figure 3, where the instrument readings (right or left) relative to the response from unbonded aluminum plate are given on the *x*-axis. The application of the Fokker Bondtester was widespread during the 1960s and early 1970s. Even though the instrument is still widely used for NDE of bonds, the unreliability of the predictions has caused it to be phased out for use in strength measurements.

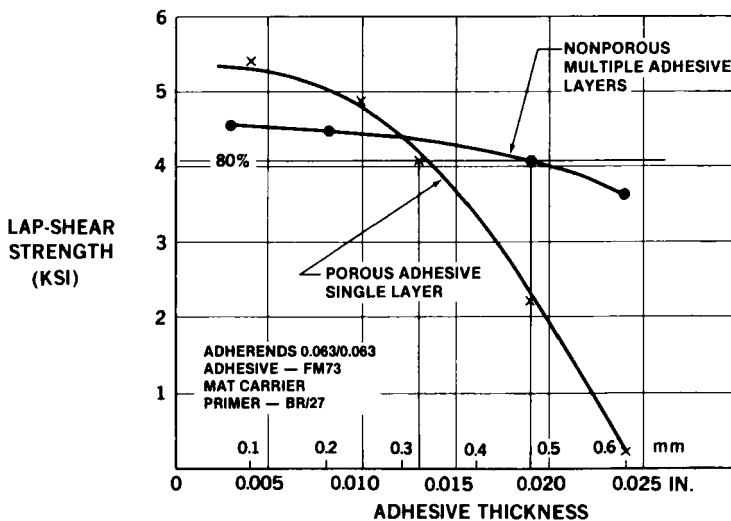

FIGURE 2 Lap-shear strength versus adhesive thickness for porous and non-porous adhesives (Ref. 6).

Downloaded At: 15:08 22 January 2011

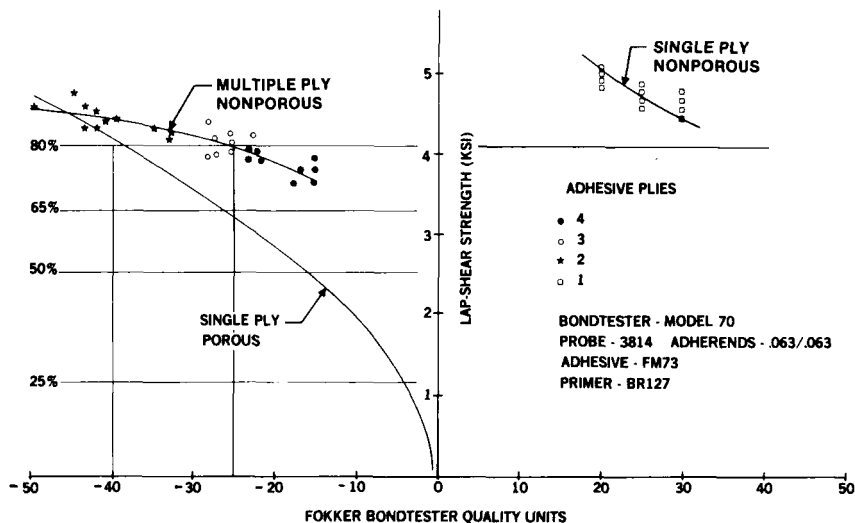

FIGURE 3 Lap-shear strength versus Fokker Bondtester "Quality" units (Ref. 6).

**ULTRASONIC PULSE-ECHO AND THROUGH-TRANSMISSION**

A wave traveling from one material to another will be partially reflected and partially transmitted through the interface. The amplitude of each of the two generated components of the wave is determined by the degree of mismatch in the acoustic impedance between the two materials.

The reflection and transmission coefficients for the intensity of a wave incident normal to an interface between two half-spaces are

$$R = \left( \frac{z_1 - z_2}{z_1 + z_2} \right)^2 \tag{2a}$$

$$T = 1 - R \tag{2b}$$

where  $z_1, z_2$  are the acoustic impedances of the two materials, defined through the relation,

$$z_j = \rho_j v_j, \quad j = 1, 2$$

The larger the impedance mismatch between the two materials, the higher the reflected amplitude, which is proportional to the reflection coefficient. As an example, if aluminum is bonded to an adhesive layer of epoxy, then  $R \approx 0.16$ ; if the aluminum is not bonded then, at the aluminum-air interface,  $R = 1$ , *i.e.*, a total reflection occurs. On the other hand, if water penetrates the unbonded area during a standard ultrasonic inspection, then the sensitivity to the unbond decreases. The above analysis can be applied to through-transmission using Eq. (2b). In the case of an unbond, the defect causes a complete blockage of the wave transmission, since  $T = 0$  for an aluminum-air interface.

These two possibilities of identifying the unbond are employed as the NDE technique, pulse-echo and through-transmission. They are used with short ultrasonic pulses and are operated at higher frequencies (0.5 to 10 MHz) than the resonance technique. For pulse-echo, a single transducer is used and access to the tested part is required only from one side; whereas, for through-transmission, two transducers are required and they need to be maintained along the wave path. To increase the detectability of defects in a through-transmission test, a reflector plate can be employed to reflect the transmitted signal back to the transducer. Thus a single transducer is used and the effect of the attenuation is increased by doubling the wave path.

Generally, the wave is transmitted from the transducer to the test part and back with the aid of a fluid couplant such as water or grease. For laboratory or shop conditions, a water column is produced by immersing the part or by injecting water between the transducer and the part surface. Under field conditions, it is difficult to maintain a water column and, therefore, the transducer is placed directly on the test part in a technique called contact coupling.

A typical pulse-echo data for a relatively thick aluminum plate and the results<sup>7</sup> theoretical calculations are shown in Figure 4; the agreement can be seen to be excellent. Similar results for a thin aluminum plate and a bonded aluminum plate are shown in Figure 5. It can be seen that the front and back reflections cannot be distinguished clearly in Figure 5(b). For a thin plate, it would be difficult to determine bond properties through the use of flight times in the pulse echo data.

Examples of the response when using pulse-echo and through-transmission techniques in more complex specimens are shown in Figures 6 and 7, respectively. Since for through-transmission measurement there is no interest in the phase of the signal, the response was rectified and presented in video form as compared to the RF form for the other cases. For through-transmission, the difference between bonded and unbonded areas is obvious from the appearance and disappearance of the received signal after traveling through the part. This technique is widely used since it is fast and covers both sides of the test structure in one test. However, it is difficult to apply the technique in field conditions

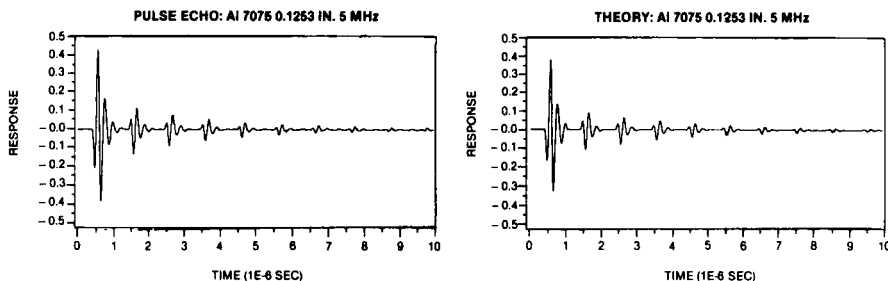
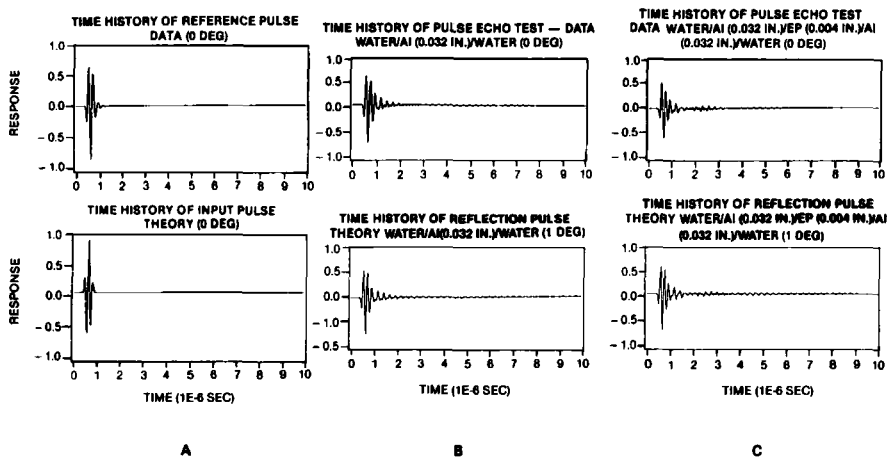
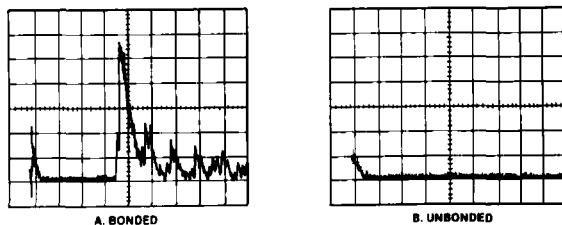

FIGURE 4. A typical pulse echo data and comparison with theory. The first pulse represents reflection from the front surface of the aluminum plate immersed in water; all other pulses are from the back of the plate.

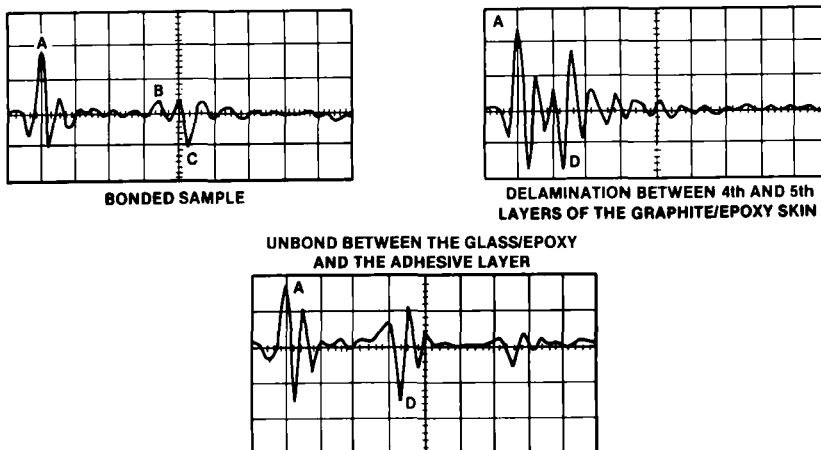

**FIGURE 5** The measured and calculated pulse echo from a thin aluminum plate. Note that, in contrast to the case shown in Figure 4, the front and back reflections cannot be clearly distinguished. Agreement between theory and experiment can be seen to be excellent.

### THROUGH-TRANSMISSION RESPONSE FROM A SAMPLE OF GRAPHITE/EPOXY HONEYCOMB SANDWICH



**FIGURE 6** Through-transmission response of a graphite/epoxy honeycomb sandwich specimen.



**FIGURE 7** Pulse echo from specimens of graphite/epoxy  $[0, 90]_{2s}$  and glass-epoxy  $[0]$ /adhesive FM73/aluminum honeycomb.



because of the required alignment of the two transducers during inspection and the need to maintain water columns for coupling. The pulse-echo technique, on the other hand, provides detailed information about the bonded areas. One can determine whether the unbond is above or below the adhesive layer or, in the case of composites, if it is an unbond or delamination. When the delamination is detected, one can determine its depth with a relatively high accuracy of  $\pm 0.1$  mm in typical specimens.<sup>7</sup> The detected defects are accepted or rejected by comparing the response from a defect to the response from a reference defect with a size defined by the material specifications. It is common to define levels of quality that depend on the defect size by the letters *A*, *B*, *C*, where *A* identifies the highest quality as used for primary structures, and *C* the lowest.<sup>6</sup>

The success of both methods is critically dependent upon the unbond gap; if the gap is much smaller than the wavelength of the ultrasonic wave, then both bonded and unbonded areas will have the same response. Assume that a layer of foreign material is sandwiched between two half-spaces of the same material. The transmission coefficient for normal incidences is given by,<sup>8</sup>

$$T = \frac{2m}{(4m^2 + (1 - m^2)^2 \sin^2 kd)^{1/2}} \quad (4)$$

where  $m = z_1/z_2$ , the degree of impedance mismatch;  $k$  = the wavenumber in the gap; and  $d$  = thickness of the gap.

The transmission coefficient (4) of the air gap between two aluminum half-spaces is shown in Figure 8. The frequency times the gap thickness is shown on the abscissa in units of mm-MHz. As shown, for 1 MHz, a gap of 5 micrometers allows very little transmission. However, if the frequency is reduced to 10 kHz, then about 25 percent transmission occurs and, therefore, the detectability of the defect is substantially reduced. This shows that unbonds can best be detected by using frequencies at which the wavelengths are sufficiently

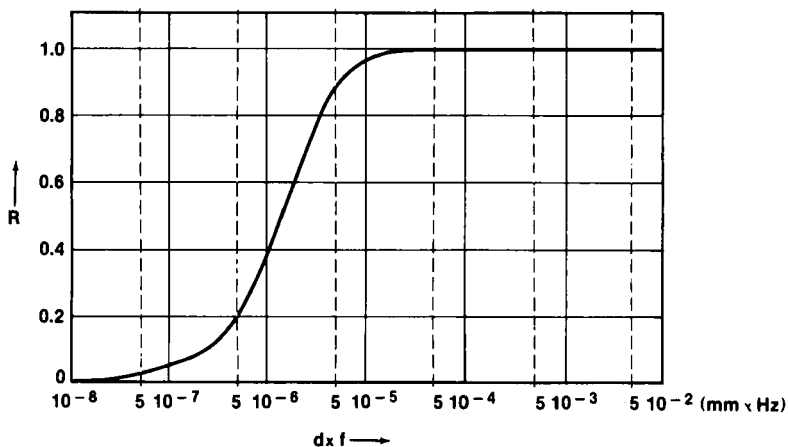

FIGURE 8 Transmission coefficient of an aluminum/air/aluminum specimen.

smaller than the suspected unbond gap. For aircraft structures, a frequency range of 1.0 to 15 MHz is in common use. Generally, an increase in the frequency is accompanied by an increased energy loss due to attenuation. Therefore, no efforts are made to increase the frequency beyond 15 MHz unless the test is performed on thin layers with low attenuation.

### ULTRASONIC SPECTROSCOPY

The signals measured by pulse-echo or through-transmission are usually examined in the time domain, using a broadband signal. The received signal can also be analyzed in the frequency domain by means of a frequency analyzer which continuously displays the transform or by a programmable signal analyzer that can perform Fast Fourier Transform (FFT). The advantage of the spectroscopy technique is its ability to reveal frequency-dependent features that cannot be easily identified in time-domain signals. Further, the signal can be processed with various enhancement techniques which improve the ability to detect the defect. Examples of such processes include filtering, convolution and correlation. This method, called ultrasonic spectroscopy, has been investigated for use as an NDE tool, mostly during the 1970s.<sup>9</sup>

The method is based on the analysis of the spectral response of the test structure as compared to the response from an unbonded system. The frequency-dependent reflection and transmission coefficients can be determined for any given number of elastic, isotropic, and homogeneous layers, by means of several well-established techniques.<sup>10</sup> A plane longitudinal wave is assumed to propagate normal to the layers. The reflection coefficient has a frequency-dependence that is related to the thickness and the elastic properties of each layer of the bonded medium. The attenuation in each layer, and specifically in the adhesive layer, can be taken into account by assuming that the wave number and the acoustic impedance are complex. The authors have developed an efficient computer code for the calculation of the frequency-dependent reflection coefficient.<sup>11</sup>

The analysis can be useful when examining the effect of the bonded and unbonded materials on the reflection coefficient. As an example, consider a specimen consisting of two identical aluminum plates bonded by a layer of epoxy. Assume that the thickness of each is 1 mm, and that the epoxy layer is 0.1 mm thick with attenuation of 10 dB/mm/MHz<sup>2</sup>. The calculated reflection coefficients as a function of frequency for several possible cases are shown in Figure 9. The predicted spectra can be compared with the actual response to determine if the aluminum layers are bonded. The bonded system has six minima within the frequency range of 1 to 10 MHz, whereas the unbonded aluminum layer has only three. These minima are a result of constructive interference of the waves within the specimen. In the time domain, a large number of minima are associated with a smaller number of reflections within a given time. Multiple reflections with a short time-of-flight can identify unbonds in an aluminum plate. They form the basis of the so-called ringing technique, widely used for NDE of bonds.

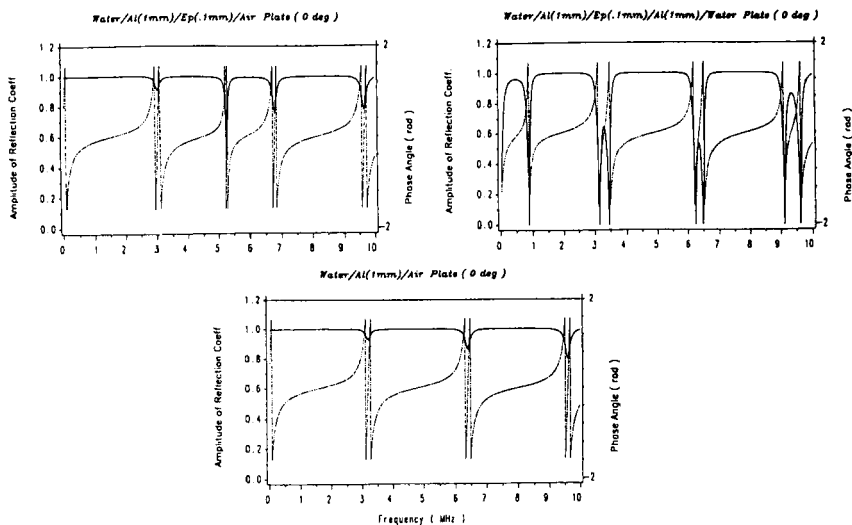

FIGURE 9 Amplitude spectra of the calculated reflection from a perfectly bonded aluminum plate (top); a plate with complete debonding at the lower epoxy-aluminum interface (middle); at the upper epoxy-aluminum interface (bottom).

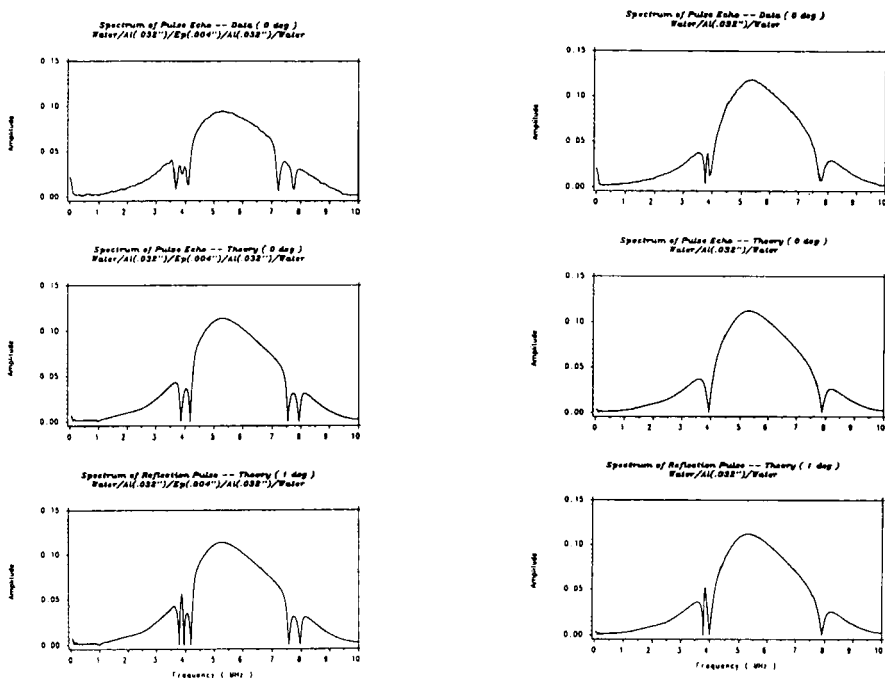

FIGURE 10 Amplitude spectra of the pulse-echo data shown in Figure 5(a, b) and calculated spectra for two angles of incidence. Note that an incidence angle of 1° produces better correlation with measured spectra.

The spectral representation of the pulse echo results presented in Figure 5 are shown in Figure 10. It can be seen that there is general agreement between the theoretical and measured spectra. A number of detailed features of the theoretical predictions are not reproduced in the measured spectra; further investigation of this is currently in progress.

### LEAKY LAMB WAVES (LLW)

In all of the previous techniques discussed above, the ultrasonic waves were incident normal to the specimen. The leaky Lamb wave (LLW) technique is based on an angular insonification of the tested solid. When a transducer insonifies a test part at an oblique angle, the wave is refracted, as well as mode-converted to induce guided waves which can be very useful in NDE. These waves, when excited, propagate along the plate and are strongly affected by the properties of the bond.<sup>11</sup>

The LLW experiment is based on two transducers in a “pitch-catch” arrangement. The test involves either immersing the part in a water tank or maintaining a water column between the transducers and the part surface. For a fixed angle of insonification, the acoustic waves are mode-converted to induce guided Lamb waves at certain specific frequencies, resulting in leakage of radiation into the fluid. When a leaky wave is introduced, the field of the specularly reflected wave is distorted. The specular part of the reflected wave and the leaky wave interfere, a phase cancellation occurs, and two components are generated with a null between them.<sup>12</sup> A schematic description of the leaky Lamb wave experiment is shown in Figure 11.

The spectral response of a uniform aluminum plate and a bonded aluminum/epoxy/aluminum plate immersed in water and insonified at 20 degrees are shown in Figure 12. The minima in all cases are associated with the excitation of LLW modes in the specimen. The agreement between theory and experiment is excellent for the unbonded plate and reasonably good for the bonded plate. The latter result indicates the need for further research on this aspect of the problem.

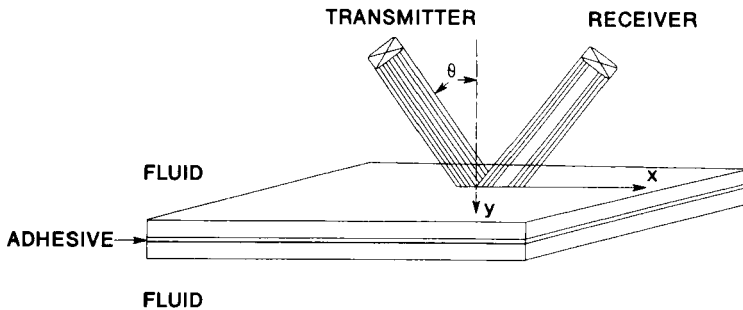

FIGURE 11 Schematic diagram of the leaky Lamb Wave (LLW) field.

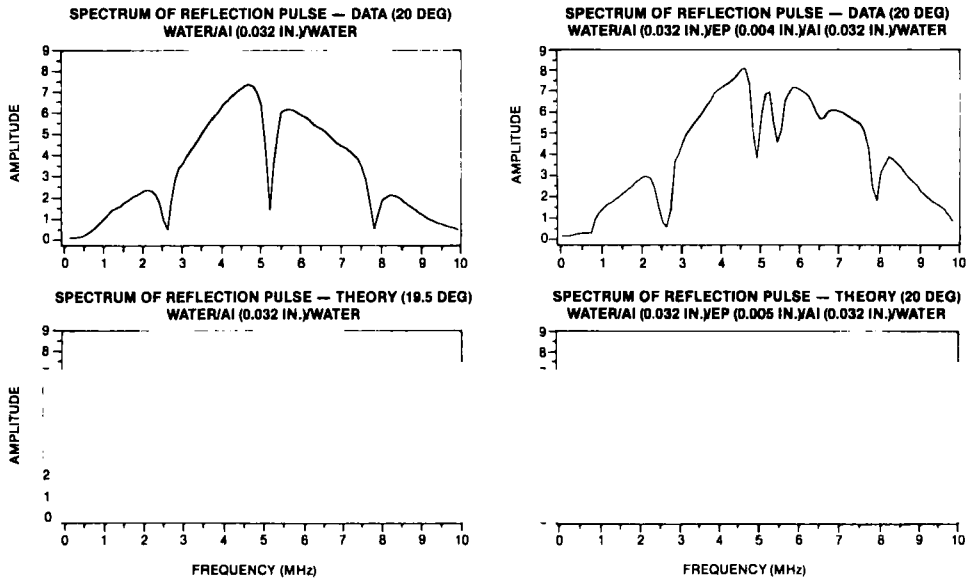

FIGURE 12 Measured and calculated LLW spectra from a uniform and bonded aluminum plate.

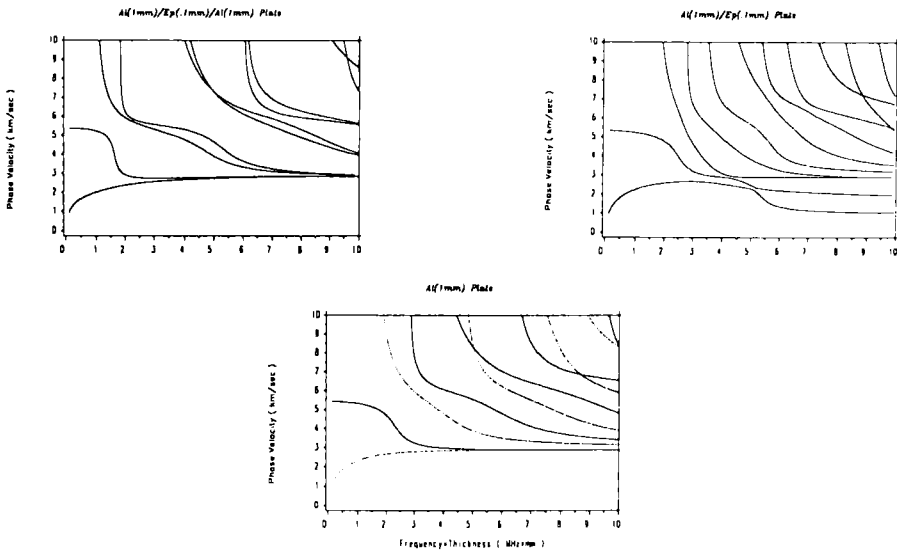

FIGURE 13. Calculated dispersion curves for Lamb waves in a bonded plate (top-left) and with debonding at the lower interface (top-right) and at the upper interface (bottom).

Downloaded At: 15:08 22 January 2011

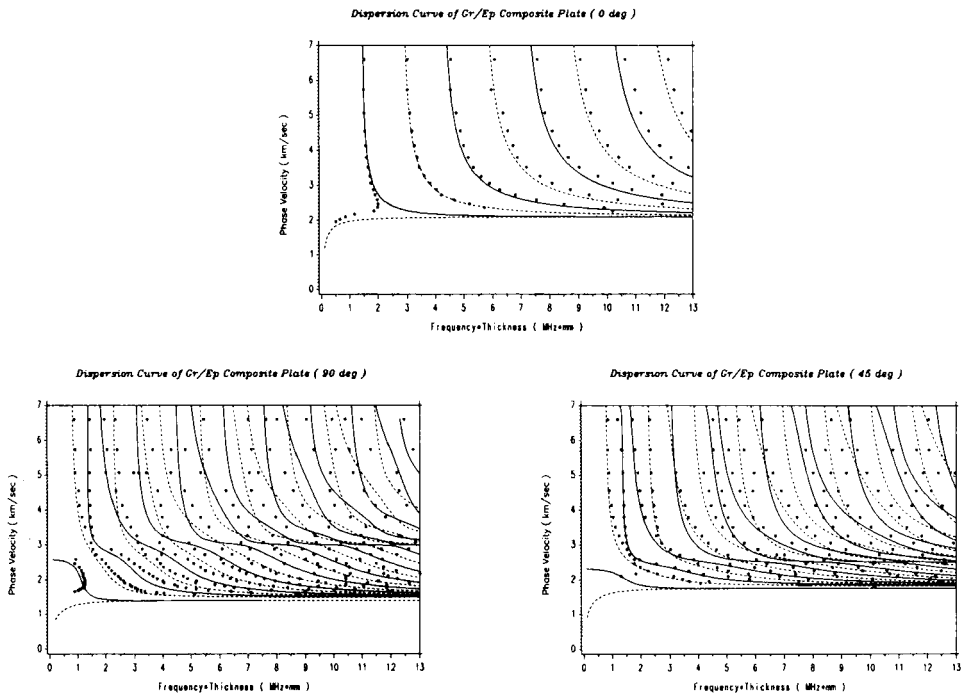

FIGURE 14 Measured and calculated dispersion curves for Lamb waves in a unidirectional graphite/epoxy composite plate for three directions of propagation relative to the fiber direction. Solid lines indicate symmetric modes, dashed lines are for antisymmetric modes.

The possible Lamb modes at various angles of incidence are given by dispersion curves. Figure 13 shows the theoretically-calculated dispersion curves for the three possible cases of the bonded aluminum plate. The measured and calculated dispersion curves for a unidirectional graphite/epoxy composite plate are shown in Figure 14. Although there is reasonable agreement between theory and experiment, further research is clearly needed to improve this.

Generally, a bonded structure can give rise to many possible modes that are a modification of those for a single layer. Therefore, for a bonded system, the excitation of the spectral response predicted for a single layer is an indication of unbond in the tested area. LLW can be used for NDE bonding by scanning an assembly and detecting areas at which the LLW modes, typical to the unbonded layer, appear. These modes are different from those of the bonded assembly.

LLW phenomena have two characteristics that make them useful for NDE of bonding. Firstly, the phase cancellation in the null zone of the LLW field is a very sensitive parameter to any change in the interface conditions. The presence or absence of bond as well as the change in the properties of the adhesive significantly alters the LLW response. Furthermore, two types of dynamic stresses, compression and shear, are generated simultaneously when a Lamb

wave travels in a plate, in contrast to only the compressional type stress in conventional NDE methods. Since the two types of stress are influenced differently by different material and defect parameters of the interface, the Lamb wave technique can provide better diagnostics of interfacial bonds than conventional NDE techniques.

Two examples of the influence of the properties of the bonding layer on leaky Lamb waves are given in Figures 15(a) and (b). In Figure 15(a) the reflected amplitude spectra from a single-layered half space are shown for three possible cases; namely, perfect bond, "weak" bond and complete debond at the interface. The strong influence of the bond quality on the location of the minima spectra can easily be seen. In Figure 15(b) the dispersion curves for the same bonded system are shown. The influence of the elastic properties of the bonding layer on the Lamb wave phase velocity can be seen to be significant in a specific frequency range. Although these are measurable effects, no controlled laboratory experi-

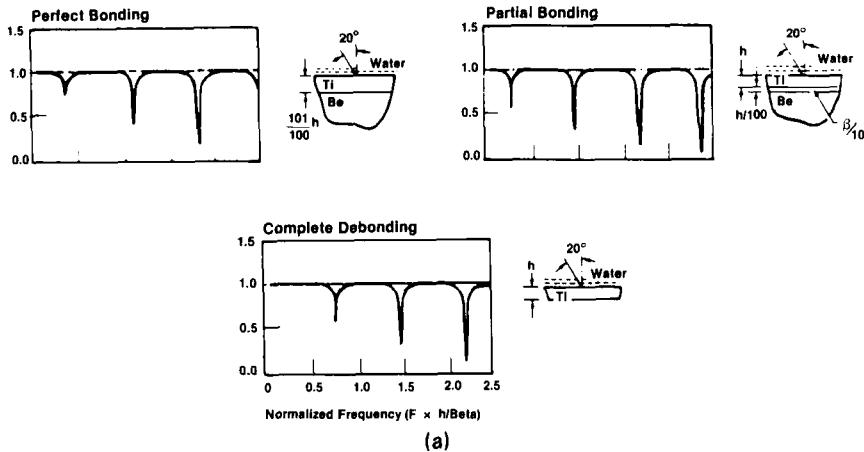

**DISPERSION CURVES**  
 TI (0.04 mm) /INTERFACE (0.0004 mm) /Be (HALF SPACE)

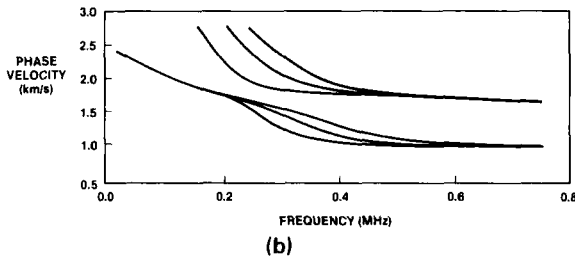

**FIGURE 15** The influence of bond properties on the phase velocity of Lamb waves. The single-layered medium consists of a layer of Titanium bonded to a Beryllium substrate, with perfect bonding, with a thin low-velocity interfacial layer and with complete debonding at the interface. The reflection amplitude spectra for the three cases are shown in (a), and the corresponding dispersion curves for the first two modes in (b).  $\beta$  is the shear wave speed in Titanium.

Downloaded At: 15:08 22 January 2011

ments have yet been performed on bonded systems. A series of such experiments are currently being designed at the NDE facilities of Douglas Aircraft.

Various applications of the LLW phenomena for NDE of bonding have been investigated. In the area of composites, a precured sandwich of AS4/3501-6  $[0, 90]_{2s}$  skins with a 12.7 mm high, 3.2 mm cell of Nomex<sup>®</sup> honeycomb with simulated unbonds made of Teflon<sup>®</sup> wafers of 25.4, 19.1, 12.7 and 6.4 mm diameter<sup>13</sup> was prepared. The sample was insonified at 15 degrees and the LLW modes were measured. A C-scan system was connected to the LLW setup and the amplitude was recorded as a function of location. The test was conducted at 5.31 MHz, which represents one of the LLW modes in the unbonded skin as a layer. The test results are shown in Figure 16, where the unbonds are clearly identified due to the generation of LLW mode which, in turn, creates a null that is detected by the receiver.

Another area, in which conventional NDE is experiencing difficulties, is the detection of unbonds between metals and rubber. These difficulties are the result of low acoustic impedance of rubber and the high mismatch in the acoustic impedance between rubber and metals. This makes the difference in the reflected signal from bonded and unbonded rubber relatively small. Since the LLW method is based on measurement of the amplitude of the null due to a phase cancellation, it is very sensitive to changes in the boundary conditions.<sup>14</sup> A 6.4 mm thick steel plate bonded to a 3.2 mm thick rubber mat has been tested with the pulse-echo technique at 10 MHz and with the LLW technique at 4.63 MHz. The results are shown in Figures 17 and 18, respectively. The pulse-echo technique shows a relatively small difference, which is at the level of the material variations across the bonded area. On the other hand, the unbond is clearly indicated when using LLW.

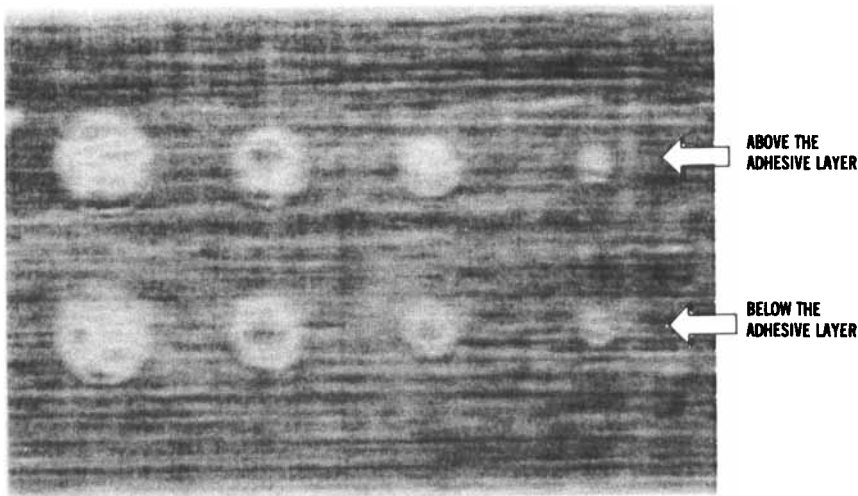

FIGURE 16 LLW C-scan image of unbonds in a sandwich of graphite-epoxy skin on a Nomex<sup>®</sup> honeycomb substrate (Ref. 13).



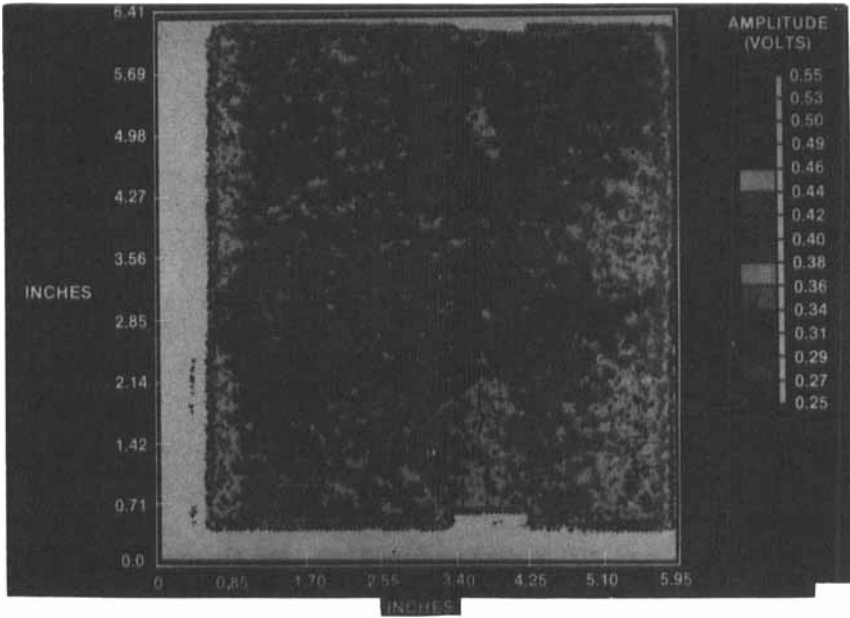

FIGURE 17 Pulse-echo C-scan image of steel/rubber bond with a 12.7 mm wide unbond. See color plate I.

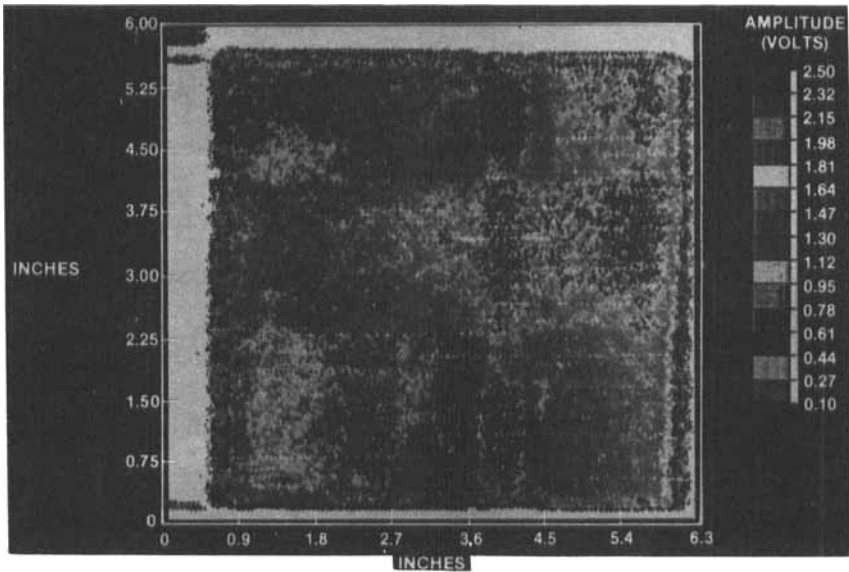

FIGURE 18 Leaky Lamb Wave C-scan of a steel/rubber bond (Ref. 14). See color plate II.

Downloaded At: 15:08 22 January 2011

Due to the anisotropy of the rolled steel plate, the frequency of LLW modes changes with the orientation of the wave propagation relative to the grain direction. Further, when insonifying a rolled steel plate normal to the grain direction, grain scattering is observed. This scattering reduces the signal-to-noise ratio at the null zone and the difference in response between bonded and unbonded areas. These effects at grain orientation need to be taken into consideration when performing a routine test.

## TECHNOLOGY ASSESSMENT

As discussed in this paper, state-of-the-art technology would not provide any physical parameter that can be directly correlated with the bond strength for a practical NDE method. NDE techniques are more capable of detecting unbonds either at the adhesive layer or at its interface with the adherends. Since bond strength strongly depends on the quality of the surface preparation, an NDE method of determining the quality of the surface preparation, such as the presence of contamination, is essential.<sup>15</sup>

Ultrasonic NDE methods are capable of providing information about adhesive bond properties, but not all relevant parameters in the detected signals are being used at present. An increase in the signal acquisition speed, an improvement in signal processing techniques and an increase in the size of, and speed of access to, computer memory are expected to improve the capability of the technique. The improved NDE techniques should allow several parameters to be captured while the bonded area is being scanned, and to examine features that enable an assessment of the bond thickness, elastic properties, presence of gross defects, etc.

Presently, pulse-echo and through-transmission are the most widely used NDE techniques for bonding in a production environment, whereas resonance and pulse-echo are used in field conditions. An increase in the usage of the LLW method is expected due to its superiority in special cases, such as steel/rubber and composite bonds. For composites, LLW has so far been found useful for laminates with limited types of fiber orientations. Development of theoretical analysis of wave propagation in anisotropic, multilayered media would lead to a better understanding of wave behavior.<sup>16-18</sup> Such a development should allow LLW modes to be predicted for bonded and unbonded laminates, which are presently too complex to interpret for multilayered laminates. Another area that will benefit from advances in analytical capability is NDE of the bond between steel and rubber, where the anisotropy of the steel reduces the efficiency of the LLW method.

## Acknowledgment

This research was partially supported by the Office of Naval Research under Contracts N 00014-87-K-0351 and N 00014-87-C-0853. The authors wish to thank Dr. Yapa D. S. Rajapakse of ONR for helpful discussions.

**References**

1. P. Cawley and R. D. Adams, *J. Sound and Vibr.*, in press.
2. J. L. Rose and P. A. Meyer, *Mat. Eval.* **31**, 109 (1973).
3. R. J. Botsco and R. T. Anderson, *Adhesives Age*, 22–25 (1984).
4. NDT Instruments, Inc., (Huntington Beach, California, U.S.A., March 1982), Report No. 2100.
5. C. V. Cagle, *Mater. Eval.* **24**, 362–370 (1966).
6. D. J. Hagemaiier, “NDT of Adhesive Bonded Structure,” presented to the Air Transport Association of America, 1977 NDT Forum, Hartford, Connecticut, September 13–15, 1977. Published by Douglas Aircraft Company as Paper No. 6652.
7. Y. Bar-Cohen, U. Arnon and M. Meron, *SAMPE J.* **14**, 4–8 (1978).
8. J. Krautkramer and H. Krautkramer, *Ultrasonic Testing of Materials* (Springer-Verlag, New York, 1969), pp. 23–29.
9. F. H. Chang, *et al.*, *IEEE Trans. on Sonics and Ultrasonics* **SU-23**, 334–338 (1976).
10. L. M. Brekhovskikh, *Waves in Layered Media* (Academic Press, New York, 1960), pp. 61–68.
11. A. K. Mal, C.-C. Yin and Y. Bar-Cohen, in *Review of Progress in Quantitative NDE 7*, D. O. Thompson and D. E. Chimenti (Eds.), (Plenum Press, New York, 1987).
12. A. Schoch, *Acoustica* **2**, 1–17 (1952).
13. Y. Bar-Cohen and D. E. Chimenti, in *Review of Progress in Quantitative NDE 5B*, D. O. Thompson and D. E. Chimenti (Eds.), (Plenum Press, New York, 1968), pp. 1199–1206.
14. C. M. Teller, K. J. Diercks, Y. Bar-Cohen and N. Shah, “Nondestructive Evaluation of Adhesive Bonds,” presented at 16th Symposium on Nondestructive Evaluation, Sponsored by SWRI and ASNT, San Antonio, Texas, April 21–23, 1987.
15. L. J. Hart-Smith, “Adhesive Layer Thickness and Porosity Criteria for Bonded Joints,” Air Force Wright Aeronautical Laboratories, Report No. AFWAL-TR-83-4172 (1982).
16. A. K. Mal, *Wave Motion* **10**, 257–266 (1988).
17. S. Rokhlin, *J. Appl. Phys.* **52**, 2847–2851 (1981).
18. A. Pilarski, *J. Appl. Phys.* **63**, 300–307 (1988).